

PERSPETIVA ISOMETRICA

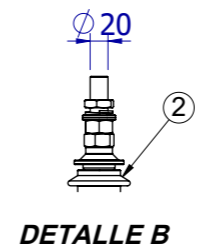
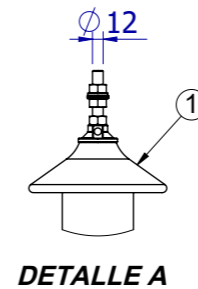
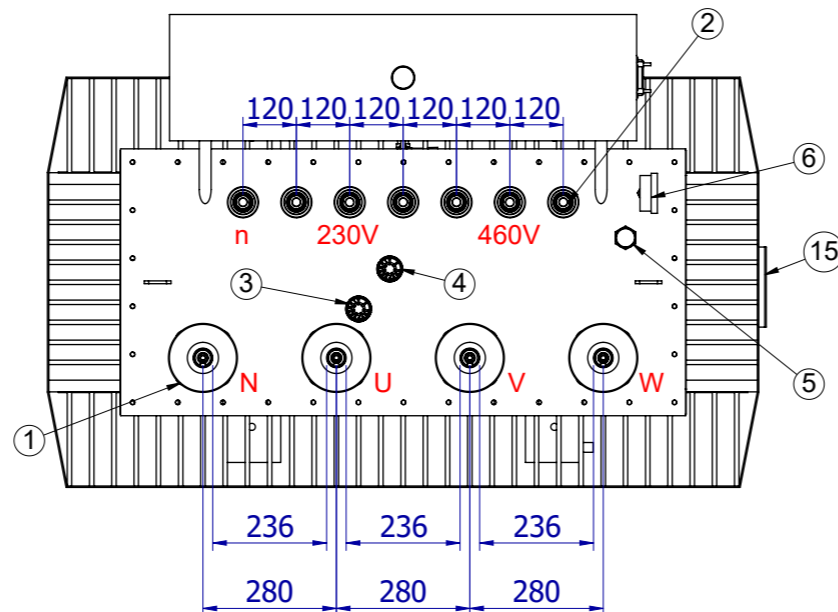

PARTE ACTIVA	1100
ACEITE	685
TOTAL	2520

ITEM	PIEZA	DETALLES	CANT.	UND.
1	Aislador MT	24KV 250A (04 aletas)	4	PZA
2	Aislador BT	1KV 630A / 1KV 1000A	3 / 4	PZA
3	Conmutador de regulación	L70 24KV (05 posiciones)	1	PZA
4	Conmutador de Cambio de tensión	L100 24KV (02 posiciones)	1	PZA
5	Valvula de alivio de presión	50kPA	1	PZA
6	Termometro	Termometro S/C	1	PZA
7	Indicador de nivel de aceite	Tipo mica (04 pernos)	1	PZA
8	Deshumecedor	Silicagel	1	PZA
9	Valvula de vaciado	1/2"	1	PZA
10	Tapon macho de seguridad de vaciado	1/2" FoGo	1	PZA
11	Tapon hembra de llenado/transporte	1" FoGo	1	PZA
12	Oreja de izaje	-	2	PZA
13	Borne de puesta a tierra	Perno 1/2" x 1 1/2"	2	PZA
14	Canal de fijación	Canal U 5"	2	PZA
15	Placa de características	-	1	PZA
16	Ruedas bidireccionales	-	4	PZA